

CPP-35 Series - CPP-35, CPP-35B



- Conductive Plastic Angle Sensor
- Effective Electrical Travel : 340°
- Independent Linearity : ±1%
- Servo Mount & Screw Mount
- Shaft :
 - CPP-35 : φ4mm Shaft
 - CPP-35B : φ6mm Shaft
- 【Options】
- Independent Linearity : ±0.2%
- Multi Ganging : More than 3 sections, please contact us.
- Additional Center Tap : C.T(A) ... No shorted angle
C.T(B) ... Shorted on Tap (Shorted angle 1~5°)
- 【Material】
- Housing : Aluminum
- Shaft : Stainless Steel
- Ball Bearing : Stainless Steel

■ Dimension [mm]

CPP-35

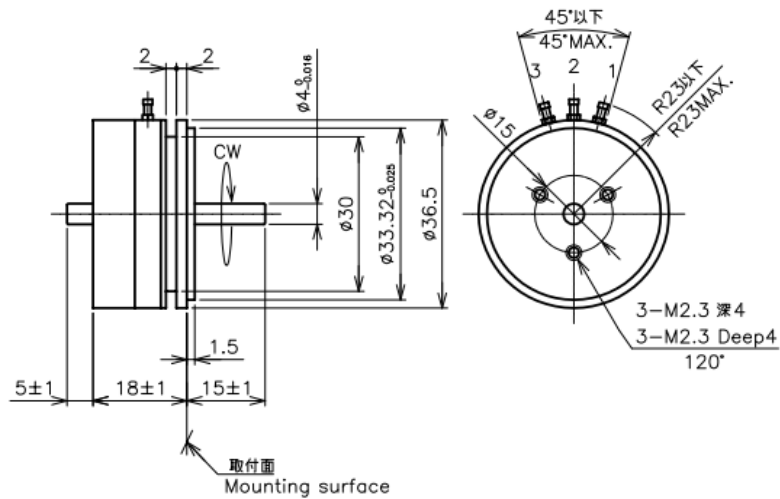

CPP-35B

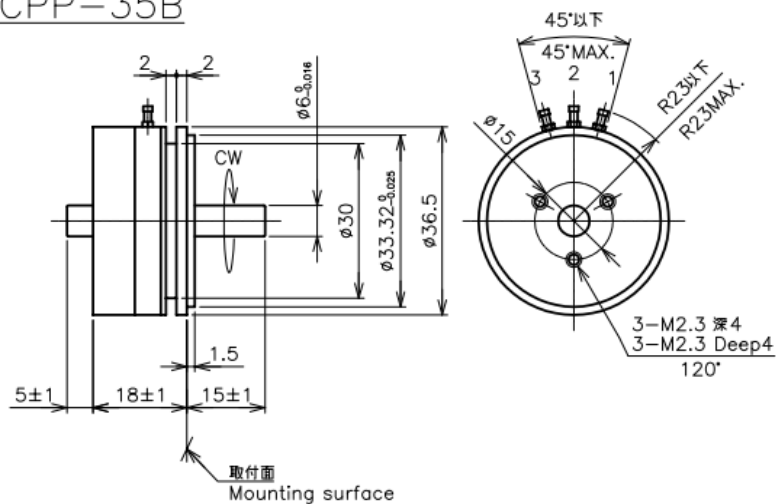

■ Output Characteristics

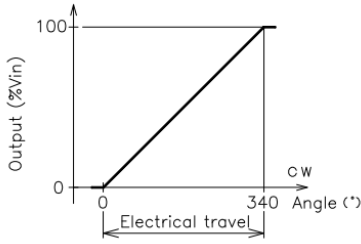

■ Schematic

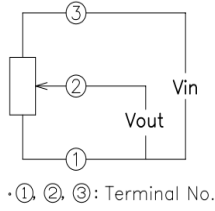

■ Mounting

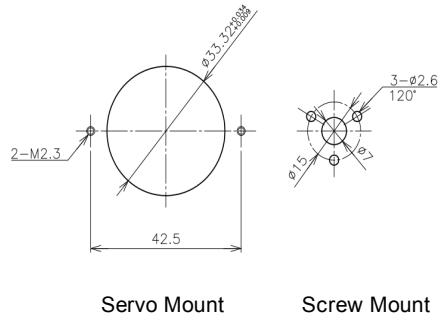

【Model No.】	CPP-35 <φ4mm Shaft>	CPP-35B <φ6mm Shaft>
-------------	------------------------	-------------------------

【Electrical Specifications】

Effective Electrical Travel	340 +2, -3	°
Total Resistance	0.5, 1, 2, 5, 10	kΩ
Total Resistance Tolerance	±20	%
Independent Linearity	±1 (Special Linearity ±0.2%)	%
Rated Dissipation	2/70°C	W
Output Smoothness	MAX. 0.1	%
Insulation Resistance	MIN. 100/DC1000V	MΩ
Dielectric Strength	AC1000/1 Minute	V
Temperature Coefficient of Resistance	±400	ppm/K

【Mechanical Specifications】

Total Mechanical Travel	360 Endless	°	
Torque	MAX. 1.4 (Additional 1.2mN·m/add one gang)	mN·m	
Thrust Load Tolerance	2	3	N
Radial Load Tolerance	4	5	N
Mass	Approx. 40 (Additional 10g/add one gang)		g

【Environmental Specifications】

Life Cycles	10 Million	Cycle
Category Temperature Range	-40 ~ +100	°C
Storage Temperature Range	-40 ~ +100	°C
Vibration	150m/s ² 2000Hz 3 axis 2 hours each	
Shock	500m/s ² 11ms 6 directions 3 times	

■ Accessories

Mounting Cleats : 2 pieces

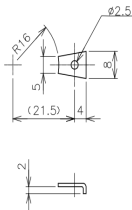

■ Handling Instruction

- To avoid burnout of resistive element, do not supply more than 1mA current to terminal 2.
- Miswiring might cause burnout of resistive element.
- To reduce sliding noise, add load resistance should be more than 100times and less than 1000times of total resistance.
- Slight continuous vibration such as dither might cause short lifetime of the sensor.